

Brain Computer Interface with g.USBamp and Simulink

Christoph Guger
g.tec medical engineering GmbH
Herbersteinstr. 60
8020 Graz, Austria
www.gtec.at
guger@gtec.at

g.USBamp is a biosignal acquisition system for EEG, ECG, EMG, EOG and other sensors. In this tutorial the usage of the device for an EEG-based brain computer interface (BCI) will be shown. The SIMULINK highspeed ONLINE processing blockset allows to read in data into Simulink in real-time and to perform the parameter estimation and classification. No additional compilation of the Simulink model is required for the on-line processing.

The corresponding Simulink model can be started from the MATLAB **Start** button.

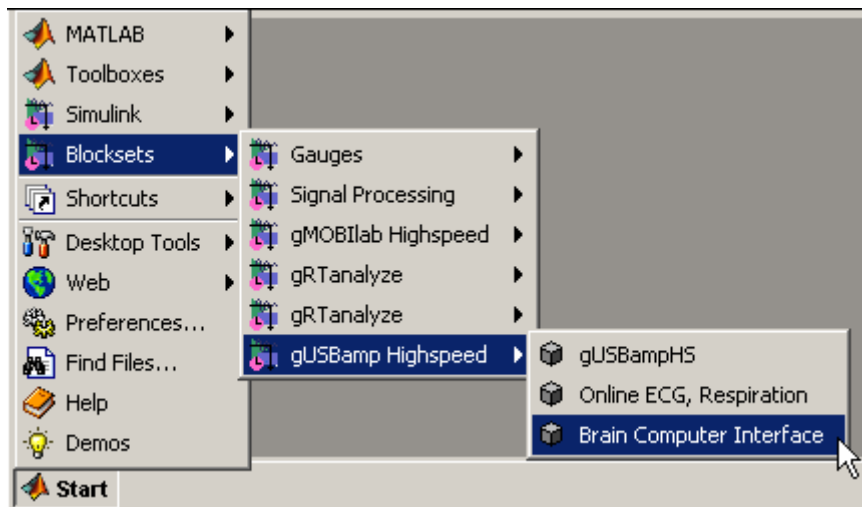

or by typing `gUSBampBCI.mdl` into the MATLAB command line.

DRIVER CONFIGURATION

Start MATLAB by double clicking on the MATLAB icon and type

```
simulink
```

into the MATLAB command line to start up the **Simulink Library Browser**:

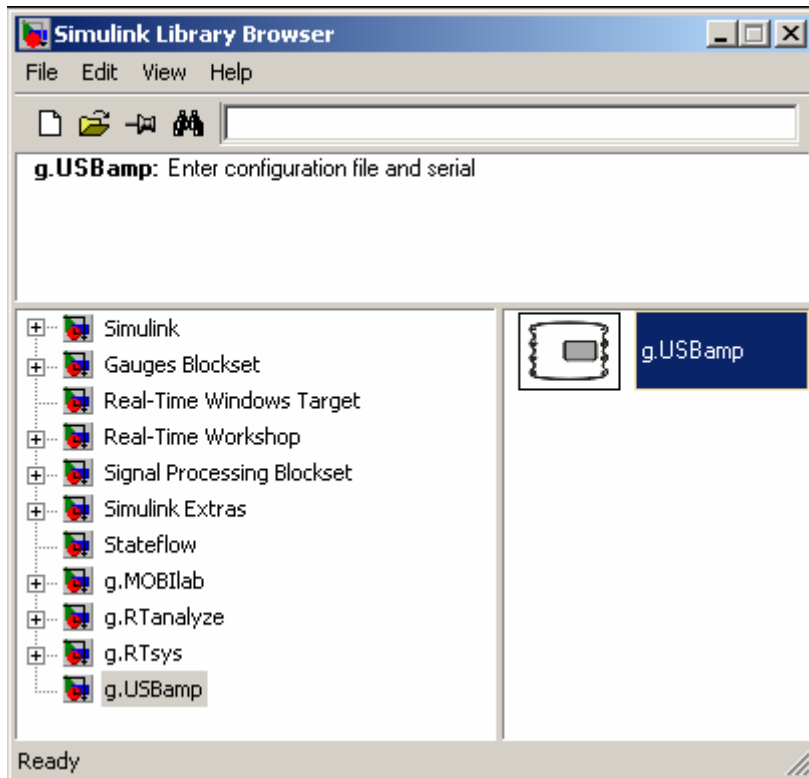

Open a new Simulink model from the **File** menu.

Then go to the `g.USBamp` folder in the **Simulink Library Browser** and drag the block **g.USBamp** into the new Simulink model.

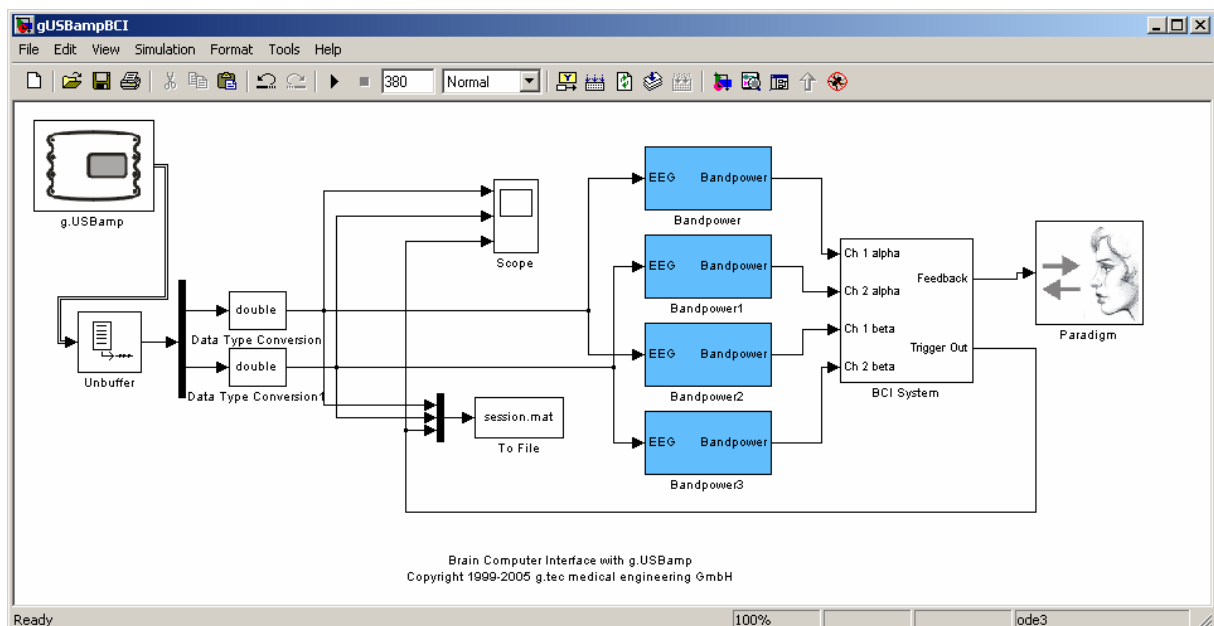

Double click onto the block to open the following window:

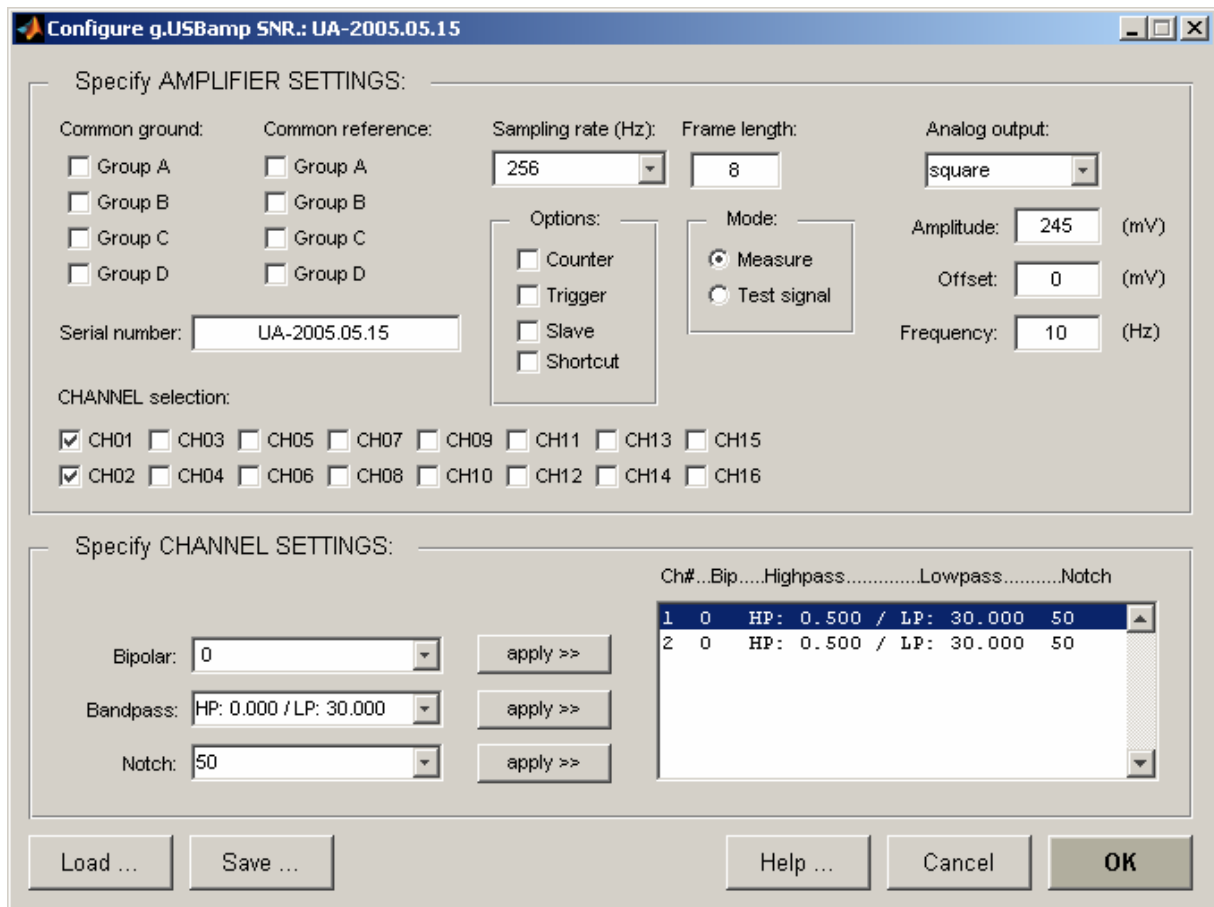

CHANNEL selection allows to specify the biosignal channels. Check channels 1 and 2. Select the **Sampling rate** 256 Hz and assign the **Bandpass** filter with a HP of 0.5 Hz and a LP of 30 Hz. Enable also the 50 Hz **Notch** filter for both channels.

Enter the serial number of the g.USBamp.

Now g.USBamp is correctly initialized.

Press **OK** to accept the settings and to close the window.

Connect the **gUSBamp** block to the **Unbuffer** block.

Connect a **MUX** block to split the two EEG channels.

The driver block reads in the data in μV and float32. Use the **Data Type Conversion** block to transform it into double format.

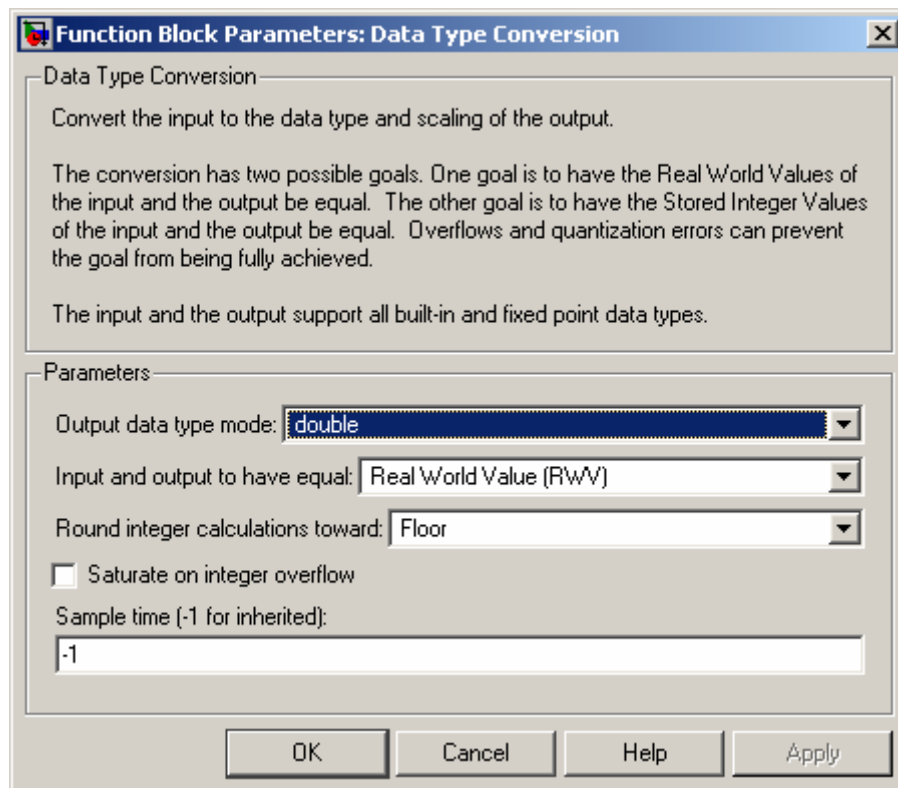

SIGNAL PROCESSING

PARAMETER EXTRACTION

Go to the **Simulink Library Browser** to the **g.RTanalyze** folder and drag the **Bandpower** block into the Simulink model.

Copy the block 3 times with the right MOUSE button.

Then connect 2 blocks to channel 1 and 2 blocks to channel 2 in order to calculate of each channel the bandpower in the alpha and beta range.

Double click on the **Bandpower** block of channel 1 and set the **Order** to 5, the **Lower cut-off frequency** to 8 Hz, the **Upper cut-off frequency** to 12 Hz and the **Window length** to 256 samples.

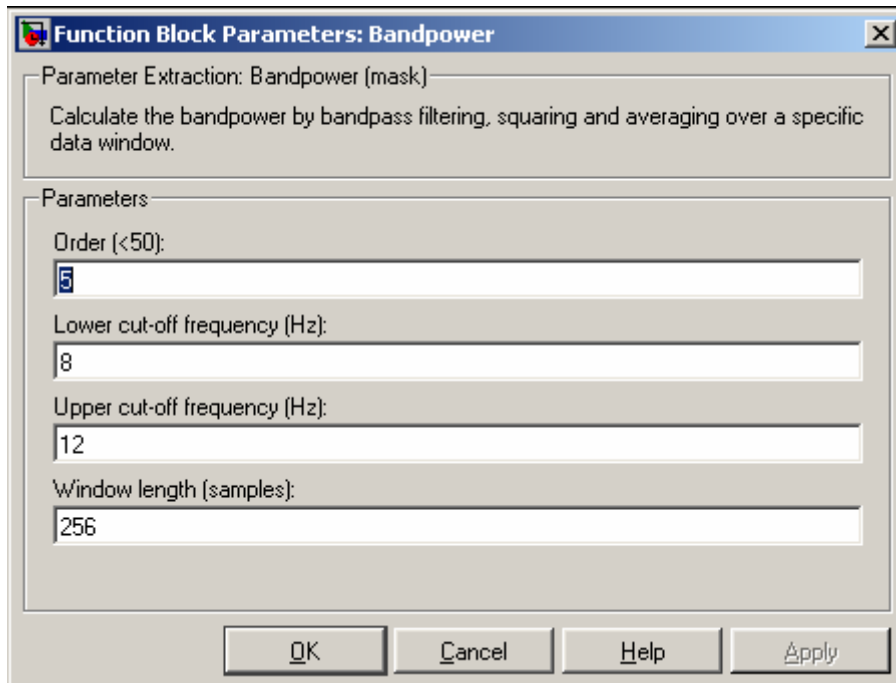

Press the **OK** button to confirm the settings and to close the window.

Double click on the **Bandpower** block of channel 1 to perform the settings for the beta range.

Set the **Order** to 5, the **Lower cut-off frequency** to 16 Hz, the **Upper cut-off frequency** to 24 Hz and the **Window length** to 256 samples.

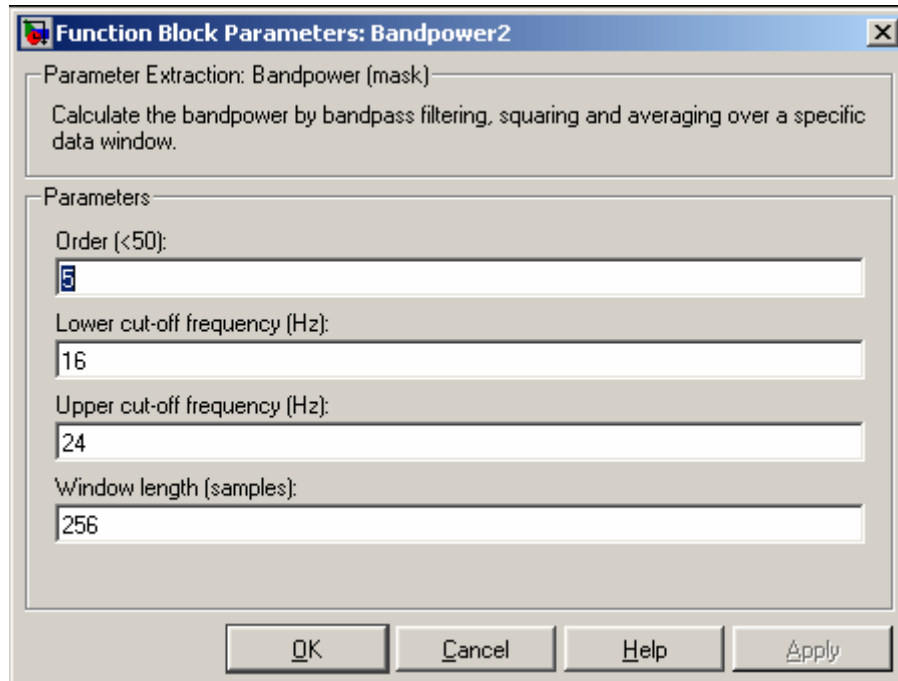

Perform the same steps for channel 2.

CLASSIFICATION

To perform an on-line classification of the parameters a linear discriminant analysis is implemented. Before weighting each parameter with the corresponding value all parameters are log transformed for normalization. Then each parameter is multiplied by its weight value and these new values are added. Finally a bias value is added. The result is a control signal that becomes positive if the subject imagines a foot movement and negative if the subject imagines a right hand movement.

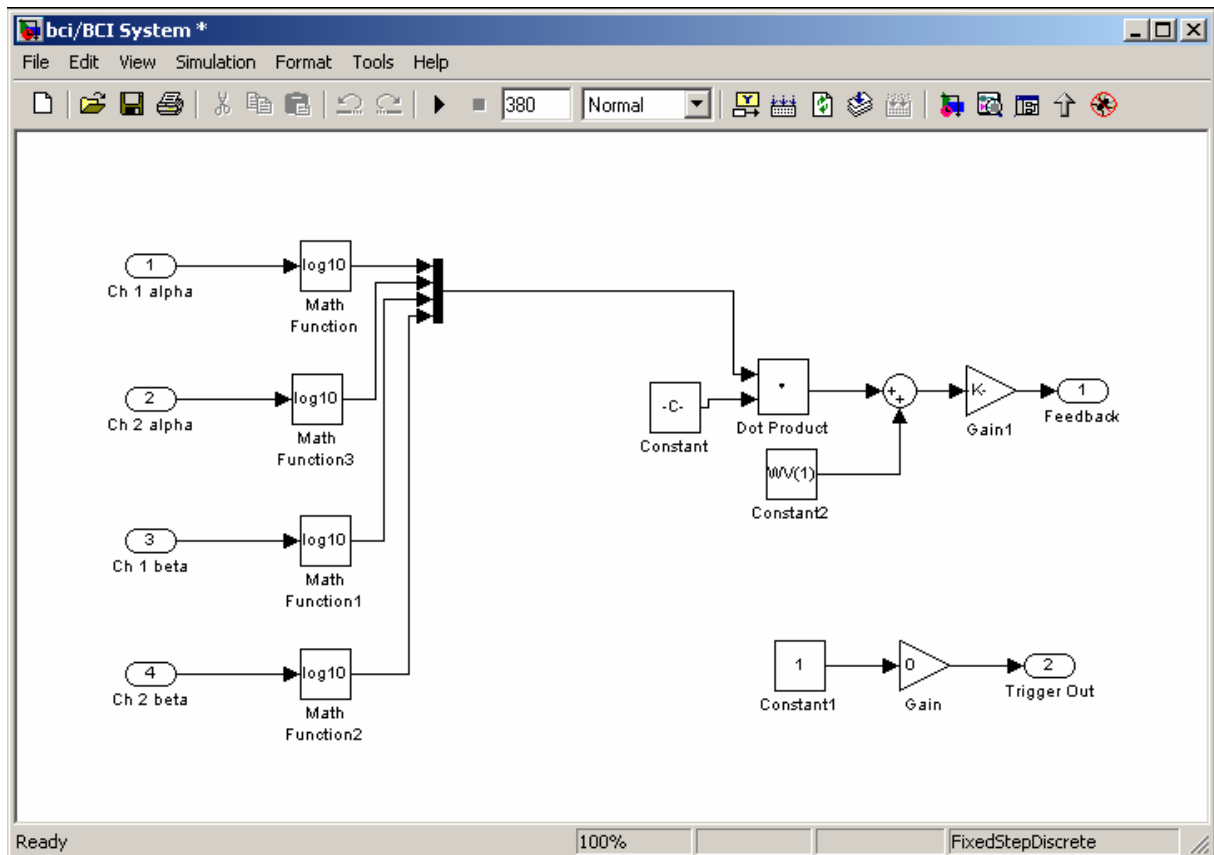

Note: the classification vector for the linear discriminant analysis must be loaded before it is possible to start the Simulink model. Set the vector $WV = \text{ones}(5, 1)$ if the BCI experiment is performed off-line. For the on-line experiment the weight vector must be calculated with `g.BSanalyze`.

PARADIGM

The output of the BCI System is connected to the **Paradigm** block. This is a MATLAB S-function which controls the experimental paradigm.

The figure shows the timing of one trial of the experiment. The subject sat in a comfortable armchair 150 cm in front of a computer-monitor and was instructed not to move and to keep both arms and feet relaxed and to maintain throughout the experiment the fixation at the center of the monitor. The experiment started with the display of a fixation cross that was shown in the center of a monitor. After two seconds a warning stimulus was given in form of a "beep" and a trigger signal was set at the output of the **Paradigm** block. From second 3 until 4.25 an arrow (cue stimulus), pointing down or to the right, was shown on the monitor. The subject was instructed to imagine a foot or right hand movement, depending on the direction of the arrow until second 8. If the experiment was performed with feedback a horizontal bar was indicating the classification result. The bar extended to the right side if a right hand imagination was performed and vice versa for the bottom side.

One trial lasted 8 seconds and the time between two trials was randomized in a range of 0.5 to 2.5 seconds to avoid adaptation. The subject performed 4 runs consisting each of 40 trials

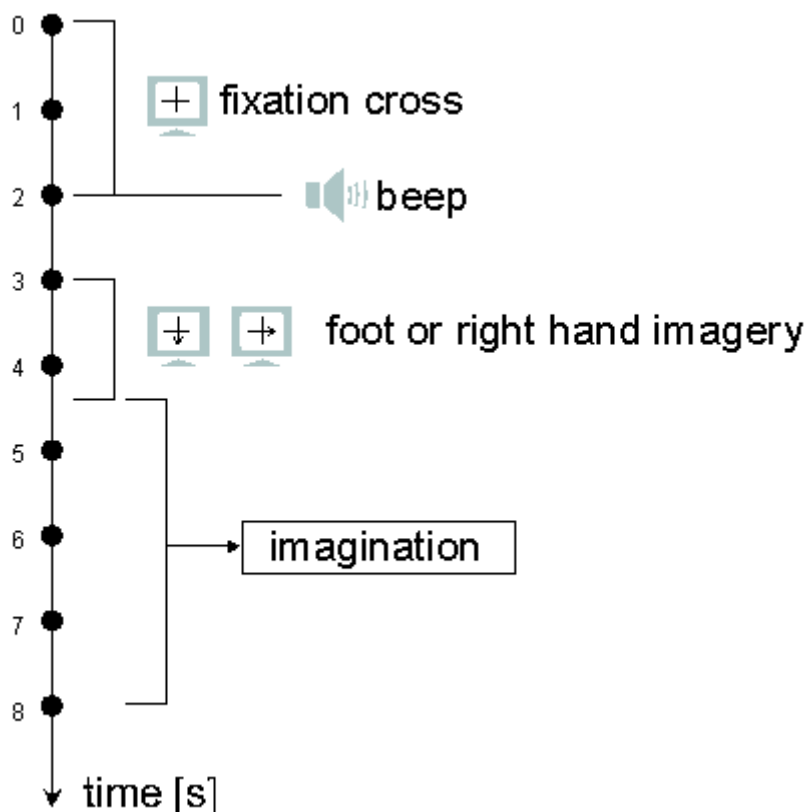

Double click on the **Paradigm** block to select if the experiment should be with feedback or without and to select the **Run** number. Note that sessions with feedback can only be performed if a weight vector was already calculated from former BCI sessions.

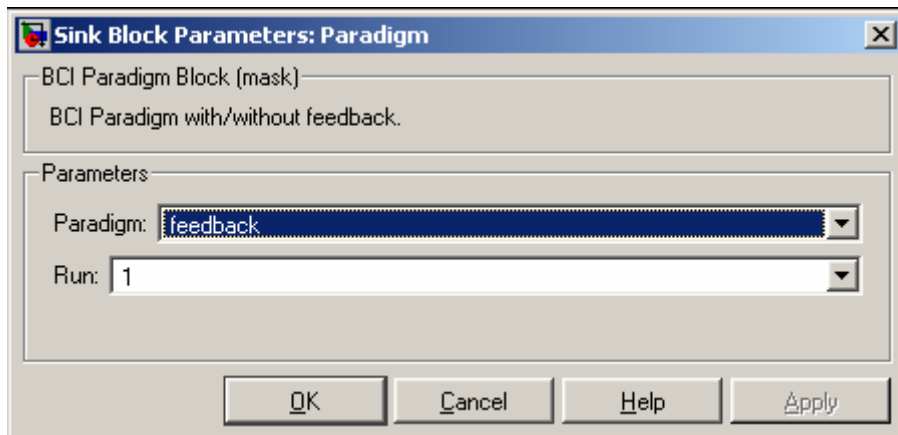

DATA STORAGE

Copy the **To file** block from the **Simulink Library Browser** into the Simulink model.

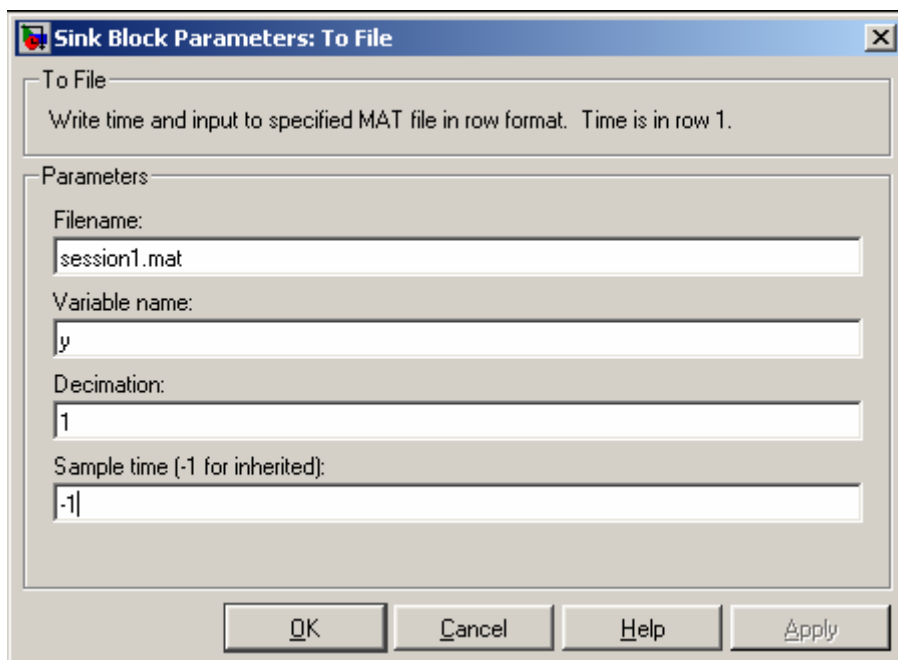

Enter under **Filename** `session1.mat` and under **Variable Name** `y`. If the **Sample time** is set to `-1` the sampling frequency is inherited from the block driving this block.

Press **OK** to close the window.

SYNCHRONIZATION

To synchronize the paradigm with the EEG data connect the **Trigger Out** output to the **To File** block. Additionally this trigger signal is connected to the **Scope** to investigate the trigger signal.

After acquiring the data the trigger signal can be used to find the beginning of each trial in the data.

OFF-LINE PROCESSING

Type into the MATLAB command window

```
gbsanalyze
```

to start the Data Editor.

Load the acquired data file `session1.mat` for the calculation of a new weight vector for the next on-line experiment with feedback.

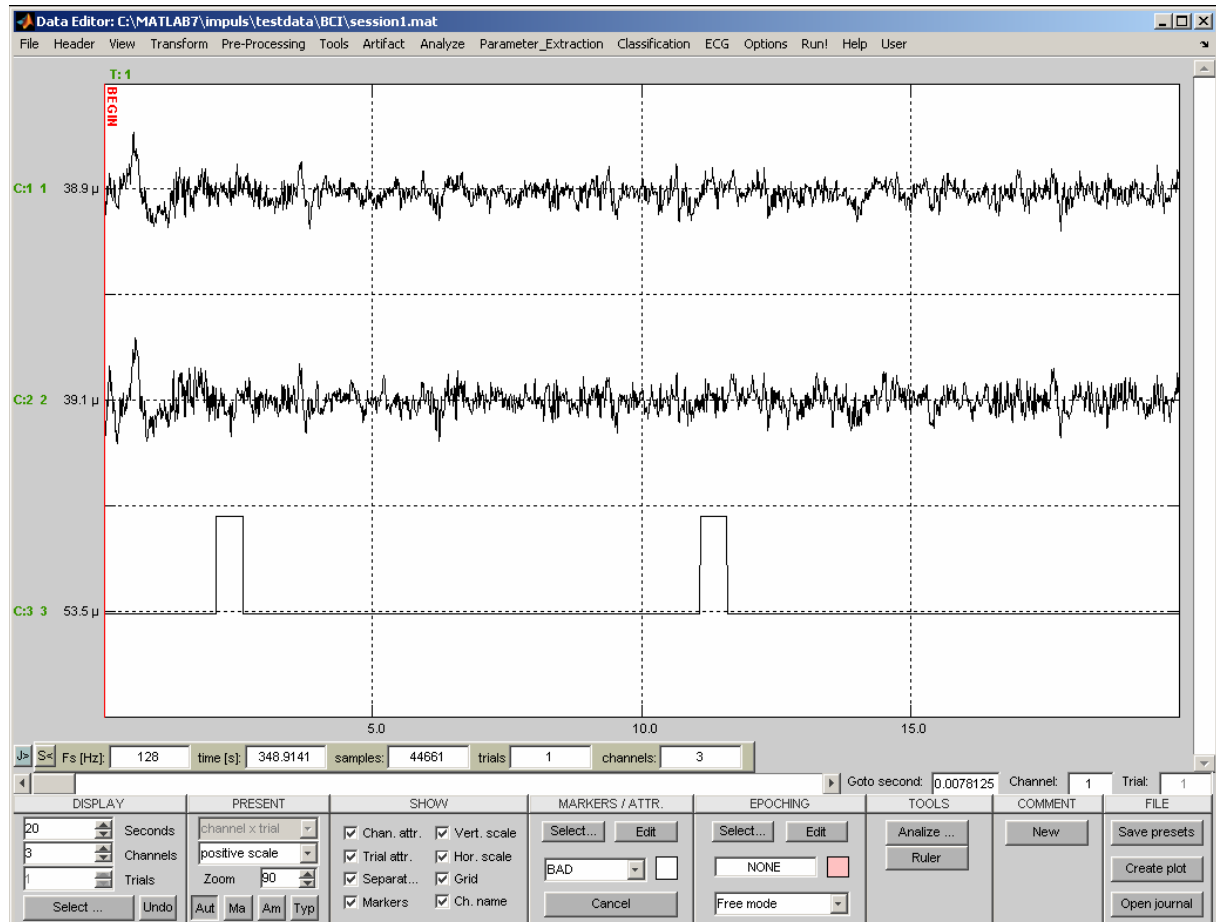

SUMMARY

The new Simulink highspeed ONLINE processing block **g.USBamp** allows the setup of an EEG based brain computer interface.

It is not necessary to compile the Simulink model for the on-line operation and therefore the development time is reduced. The new driver block allows the usage of all Simulink blocks and S-functions can be implemented as C or MATLAB S-functions.

To perform the tutorial the following components are required:

g.USBamp biosignal acquisition device

Simulink highspeed ONLINE processing blocks for **g.USBamp**

g.RTanalyze real-time parameter extraction blocks

EEG electrodes and EEG cap

PC or notebook with serial or USB connector

MATLAB 7, Simulink 6, Signal Processing Blockset.